

FIELDPILOT[®]

INSTALLATION MANUAL

Assisted Steering Hydraulic Installation Manual for
Vehicle Kit Number 91-02327

Fits Only Miller Condor



A Subsidiary of  Spraying Systems Co.[®]

FIELDPILOT®

Copyrights

© 2010 TeeJet Technologies. All rights reserved. No part of this document or the computer programs described in it may be reproduced, copied, photocopied, translated, or reduced in any form or by any means, electronic or machine readable, recording or otherwise, without prior written consent from TeeJet Technologies.

Trademarks

Unless otherwise noted, all other brand or product names are trademarks or registered trademarks of their respective companies or organizations.

Limitation of Liability

TEEJET TECHNOLOGIES PROVIDES THIS MATERIAL “AS IS” WITHOUT WARRANTY OF ANY KIND, EITHER EXPRESSED OR IMPLIED. NO COPYRIGHT LIABILITY OR PATENT IS ASSUMED. IN NO EVENT SHALL TEEJET TECHNOLOGIES BE LIABLE FOR ANY LOSS OF BUSINESS, LOSS OF PROFIT, LOSS OF USE OR DATA, INTERRUPTION OF BUSINESS, OR FOR INDIRECT, SPECIAL, INCIDENTAL, OR CONSEQUENTIAL DAMAGES OF ANY KIND, EVEN IF TEEJET TECHNOLOGIES HAS BEEN ADVISED OF SUCH DAMAGES ARISING FROM TEEJET TECHNOLOGIES SOFTWARE.



Safety Information

TeeJet Technologies is not responsible for damage or physical harm caused by failure to adhere to the following safety requirements.

As the operator of the vehicle, you are responsible for its safe operation.

The FieldPilot is not designed to replace the vehicle's operator.

Do not leave a vehicle while the FieldPilot is engaged.

Be sure that the area around the vehicle is clear of people and obstacles before and during engagement.

The FieldPilot is designed to support and improve efficiency while working in the field. The driver has full responsibility for the quality and work related results.

Disengage FieldPilot before operating on public roads or when not in use to prevent loss of vehicle control.

PREPARATION

1. Before beginning the installation, thoroughly clean the vehicle to remove dirt and contaminants that might get into the hydraulic circuit.
2. Park the vehicle on a clean, level floor with adequate clearance to work around.
3. Do not attempt to loosen any hydraulic fittings while the engine is running.
4. Allow the motor and the hydraulics to cool until it is no more than warm to the touch before proceeding.
5. Prior to loosening any hydraulic fittings, be sure to have the appropriate plugs and caps available in order to limit loss of hydraulic fluid from the open fittings.



PREVENT HYDRAULIC SYSTEM CONTAMINATION. It is essential to thoroughly clean hydraulic system fittings and hose connections prior to disconnecting or removing them. Use a spray cleaner such as “Brake Clean” to prevent hydraulic system contamination. Note that o-rings used on ORB and ORFF type fittings may be damaged by solvent cleaners such as “Brake Clean”. If a fitting is to be cleaned internally, the o-ring should first be removed and cleaned with a fiberless cloth.

IMPORTANT

TO AVOID EXCESS LEAKAGE, DO NOT TURN THE STEERING WHEEL WHILE THE FITTINGS ON THE MANUAL STEERING VALVE ARE DISCONNECTED.



WARNING: HOT, HIGH PRESSURE FLUID HAZARD. Hydraulic oil may be hot and under extreme pressure. To prevent serious injury or death, relieve system pressure and allow the system to cool before repairing or disconnecting. Wear proper hand and eye protection when searching for leaks, using wood or cardboard instead of hands. Keep all hydraulic components in good repair.







WARNING: PINCH POINT HAZARD! To prevent serious injury or death, avoid unsafe practice while manually operating hydraulic steering circuits. Keep others away and stay clear of mechanical steering linkages.

KIT CONTENTS

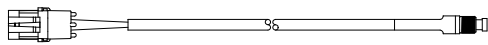
Unpack the installation kit and identify the required parts.

Item	Part Number	Description	Quantity
A	32-04040	Switch, Engage/Disengage.....	1
B	350-0037	Washer, Flat, 3/8" SST.....	4
C	35-02185	Valve, FieldPilot, PWM, 2.1GPM, OC.....	1
D	45-07703	Harness, SCM	1
E	45-10103	Harness, Valve.....	1
F	60-04089	Bolt, Hex 3/8-16 x 3-3/4" SST	2
G	60-04088	Bolt, Hex 3/8-16 X 1-1/4" SST	1
H	60-07027	Nut, NyLock 3/8-16, SST	3
I	65-05153	Bracket, Hydraulic Block Mount.....	1
J	68-01260	Hose, Hydraulic - 1/2" x 29", #8FORF x #8MORF	1
K	68-01261	Hose, Hydraulic - 1/2" x 27", #10FORF x #8FORF 90°	1
L	68-01262	Hose, Hydraulic - 1/2" x 34", #10FORF x #8FORF 90°	1
M	68-01207	Hose, Hydraulic - 3/8" x 120", #8FORF x #6FORF 90°	2
N	68-02026	Adapter, Hydraulic Run Tee - #8 ORF	1
O	68-02071	Adapter, Hydraulic Run Tee - #6 ORF	2
P	68-02128	Adapter, Hydraulic - #10MORF x #12MORB	2
Q	68-02129	Adapter, Hydraulic 90° - #10MORF x #12MORB.....	1
R	68-02159	Adapter, Hydraulic - #8MORF x #8MORB	3
S	68-02088	Adapter, Hydraulic 90° - #8MORF x #8FORF	2
T	90-50013	Cable Tie Kit, 15	1
U	91-07011	Steering Wheel Switch Kit	1
V	98-05160	Installation Manual, Miller Condor	1
W	45-05690	Cable, Sensor Extension	1

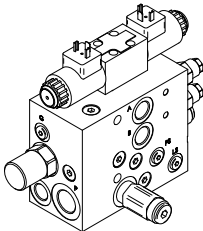
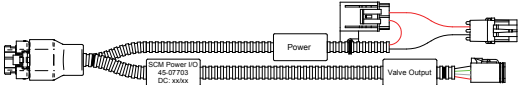
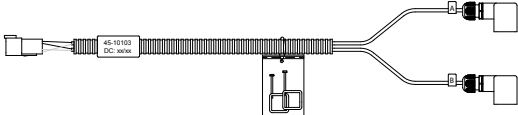
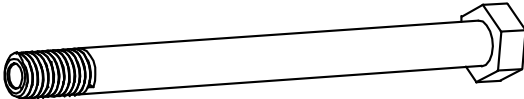
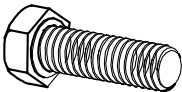
Item	Part #	Description	Illustration
A	32-04040	Switch, Engage/Disengage, Momentary	

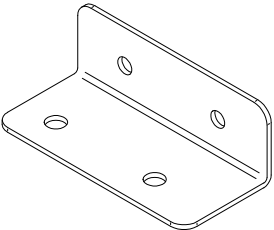
Item	Part #	Description	Illustration
B	350-0037	Washer, Flat, 3/8" SST	
C	35-02185	Valve, FieldPilot, PWM, 2.1GPM, OC	
D	45-07703	Harness, SCM	
E	45-10103	Harness, Valve	
F	60-04089	Bolt, Hex 3/8-16 x 3-3/4" SST	
G	60-04088	Bolt, Hex 3/8-16 X 1-1/4" SST	
H	60-07027	Nut, NyLock 3/8-16, SST	
I	65-05153	Bracket, Hydraulic Block Mount	

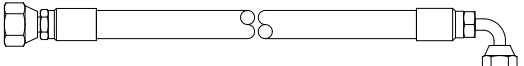
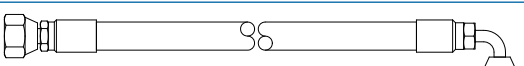
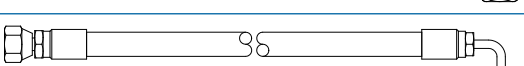
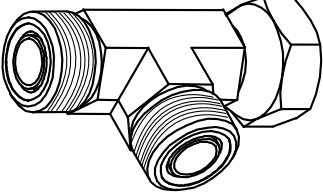
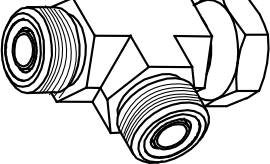
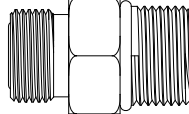
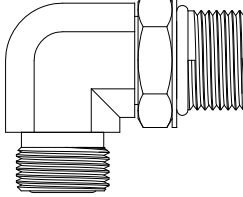
Item	Part #	Description	Illustration
J	68-01260	Hose, Hydraulic - 1/2" x 29", #8FORF x #8MORF	
K	68-01261	Hose, Hydraulic - 1/2" x 27", #10FORF x #8FORF 90°	
L	68-01262	Hose, Hydraulic - 1/2" x 34", #10FORF x #8FORF 90°	
M	68-01207	Hose, Hydraulic - 3/8" x 120", #8FORF x #6FORF 90°	
N	68-02026	Adapter, Hydraulic Run Tee - #8 ORF	
O	68-02071	Adapter, Hydraulic Run Tee - #6 ORF	
P	68-02128	Adapter, Hydraulic - #10MORF x #12MORB	
Q	68-02129	Adapter, Hydraulic 90° - #10MORF x #12MORB	

Item	Part #	Description	Illustration
R	68-02159	Adapter, Hydraulic - #8MORF x #8MORB	
S	68-02088	Adapter, Hydraulic 90° - #8MORF x #8FORF	
T	90-50013	Cable Tie Kit, 15	
U	91-07011	Steering Wheel Switch Kit	
V	98-05160	Installation Manual, Miller Condor	
W	45-05690	Cable, Sensor Extension	

Figure 1-1: Hydraulic Diagram



Existing Hoses —————

Hoses From Kit —————

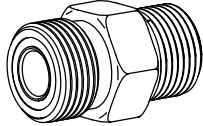
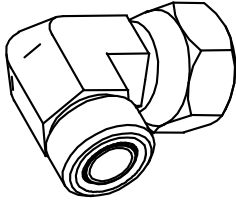
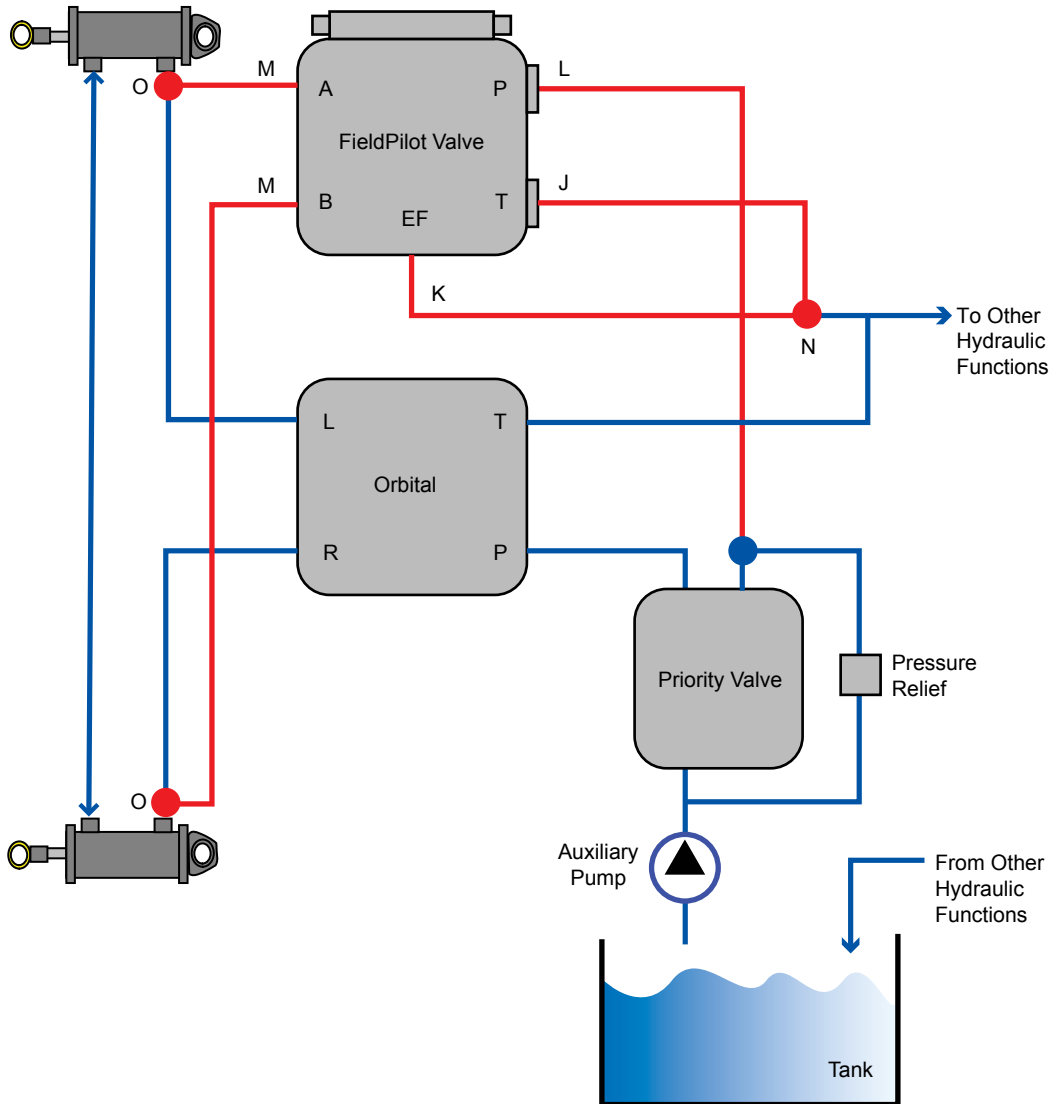
Figure 1-2: System Diagram

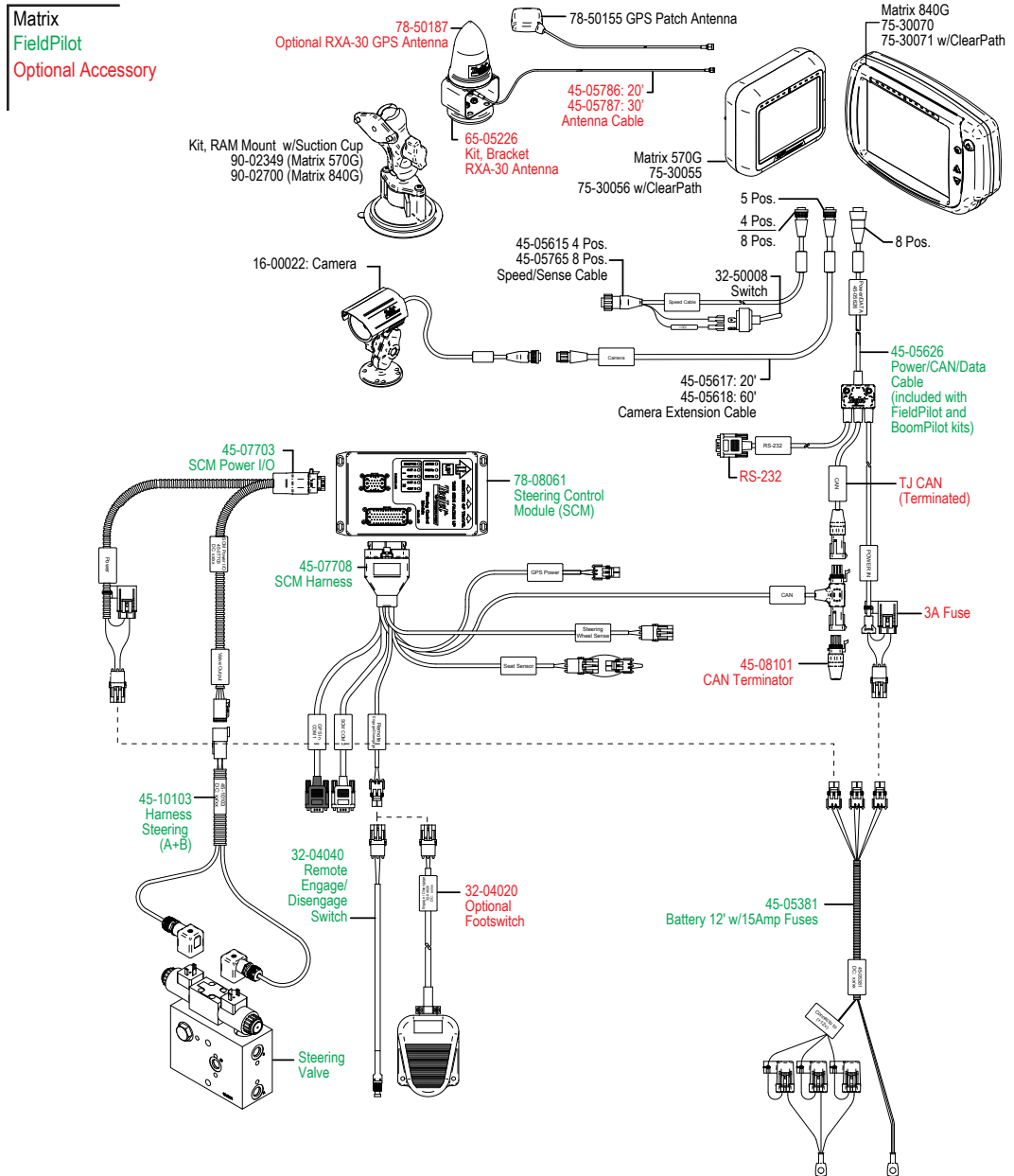

INSTALLATION



If there are questions concerning the installation of the FieldPilot system on this vehicle, or due to the changes in component specifications the parts supplied in the kit are not exactly as presented in this document, please contact your dealer or TeeJet Customer service representative for clarification before installation. TeeJet Technologies is not responsible for misuse or incorrect installation of the system.

NOTE: BE VERY CAREFUL TO ABSOLUTELY SECURE ALL CABLES AND HOSES SO THAT THEY DON'T INTERFERE WITH THE MANY MOVING PARTS OF THE MACHINE!

Overview of the Machine

- The FieldPilot valve will mount on the right side of the machine frame just under the front right corner of the cab
- The hydraulic connections will be in the same general location.
- The Excess Flow oil from the priority valve will route through the FieldPilot valve

NOTE: All references to left and right are stated as if the user is seated in the driver's seat.

Figure 1-3: Overview of the Machine



**FieldPilot Valve and
Hydraulic Connections**

1. PREPARE THE FIELDPILOT VALVE

Install adapter **(R)** in the A, B, and T ports of the FieldPilot valve **(C)**. Install adapters **(S)** on adapters **(R)** in the A and B ports. Install adapter **(Q)** in the EF port. Install adapter **(P)** in the P port.

Figure 1-4: Prepare the FieldPilot Valve

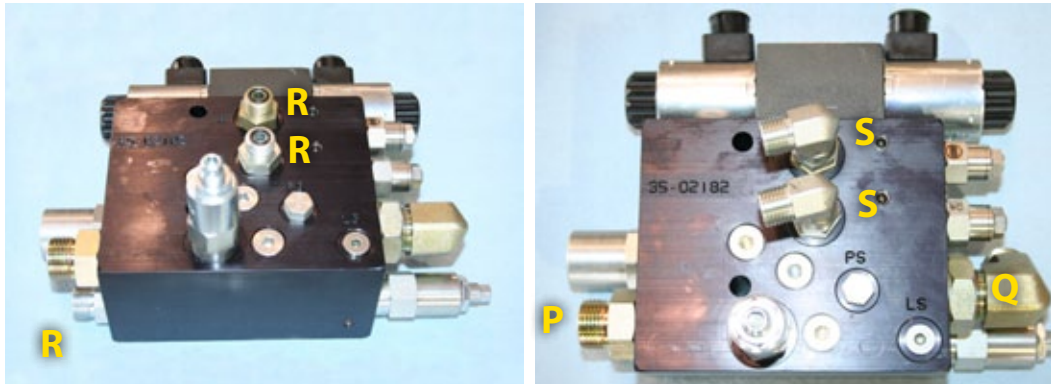

2. PREPARE THE VALVE BRACKET

Locate the front right cab support beam. Using the top of the two pre-drilled holes on the front edge of this support beam, install bracket **(I)** as shown using bolt **(G)**, two washers **(B)**, and nut **(H)**.

Figure 1-5: Prepare the FieldPilot Valve Bracket



3. MOUNT THE FIELDPILOT VALVE

Use remaining items **(B & H)** as well as bolts **(F)** to mount the FieldPilot valve to the bracket.

Figure 1-6: Mount the FieldPilot Valve

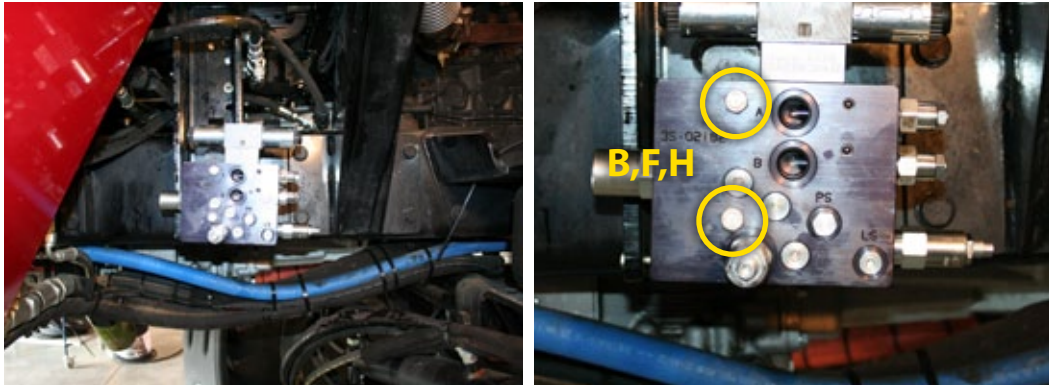

4. INSTALL PRESSURE HOSE

Locate the priority flow control valve, mounted to the inside rail of the front right cab support beam. It is on the opposite side of the beam in which the FieldPilot Valve was installed. From the T on the bottom of the priority flow control valve (Port 2), remove the pressure hose that leads to the left side of the machine feeding several hydraulic accessories. The opposite side of this T leads to port 2 of a pressure relief valve. This pressure relief valve is mounted just forward of and above the hydraulic reservoir tank.

Figure 1-7: Install Pressure Hose

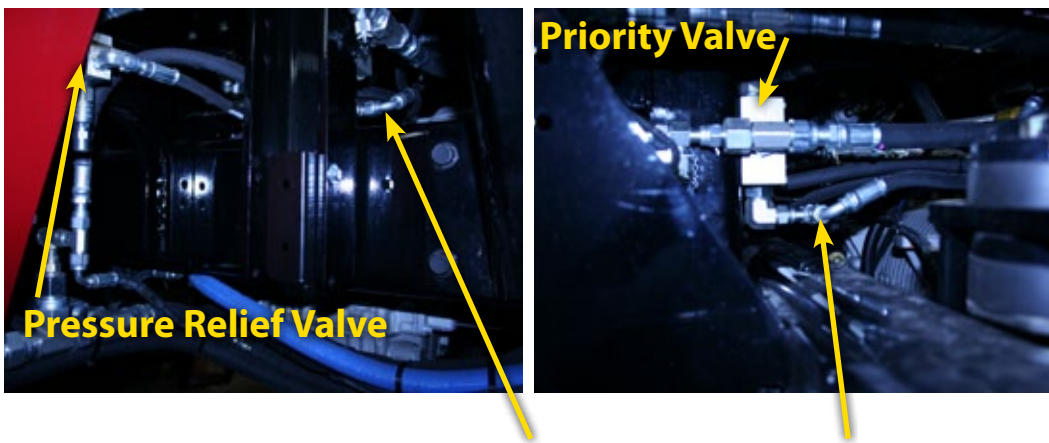

Remove this hose from Tee on bottom of the priority flow control valve

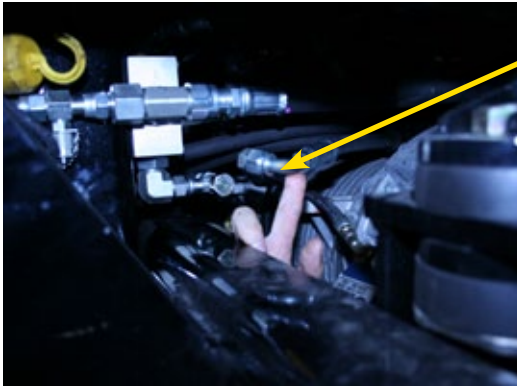

Remove this hose from Tee on bottom of the priority flow control valve

Connect the hose (L) to the P port of the FieldPilot valve. Route the 90° end of hose (L) to the now open port of the tee on the priority flow control valve.

Figure 1-8: Connect the Hose

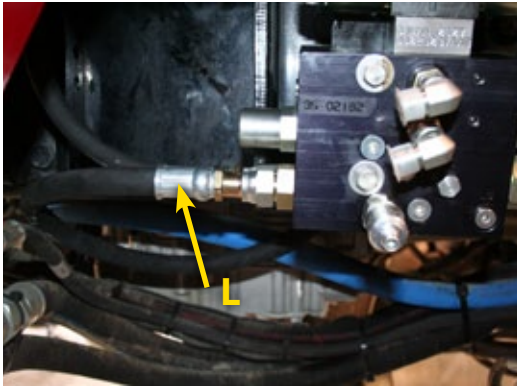

5. INSTALL TANK ADAPTERS AND HOSE

Connect run tee adapter (**N**) to the hydraulic accessories pressure hose removed from the priority flow control valve in Step 4. Connect hose (**J**) to the T port on the FieldPilot Valve. Route the other end of hose (**J**) to the run of run tee (**N**).

Figure 1-9: Install Tank Adapters and Hose

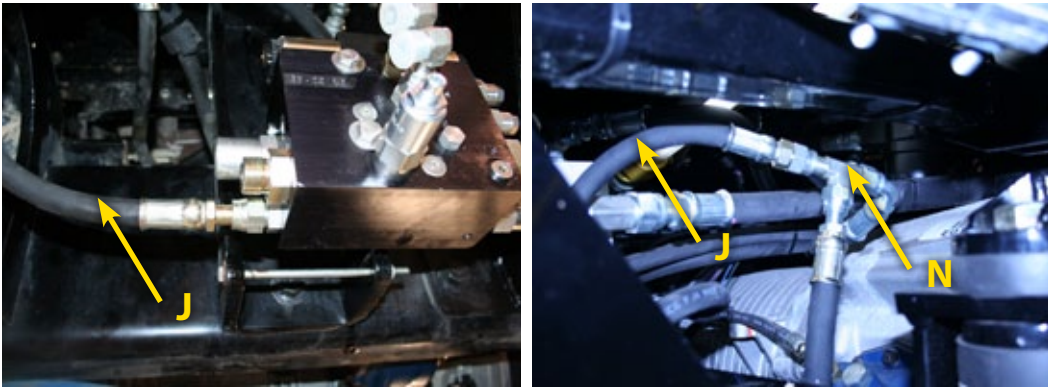

6. INSTALL EF ADAPTERS AND HOSE

Connect the hose (**K**) to the EF port of the FieldPilot Valve. Route the 90° end of hose (**K**) to the branch run tee adapter (**N**).

Figure 1-10: Install EF Adapters and Hose

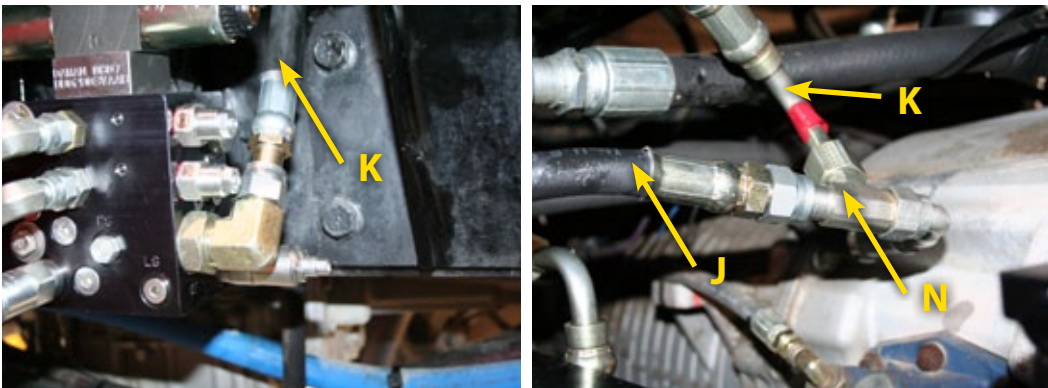

7. INSTALL STEERING HOSES AND ADAPTERS

Disconnect the steering hoses from the outside ports of the steering cylinders (both left and right). Install run tee (O) to each of the cylinders. Reconnect the steering hoses to the run of the run tee (O). Connect the 90° end of hose (M) to the branch of the run tee (O) of the left cylinder and connect the 90° end of the other hose (M) to the right cylinder. Route hoses (M) to the FieldPilot valve. Be sure to leave enough hose slack to allow for possible wheel width adjustment. Connect hoses (M) to the A and B ports of the FieldPilot Valve. Do not be concerned about which hose goes to which port on the FieldPilot valve.

Figure 1-11: Install Steering Hoses and Adapters

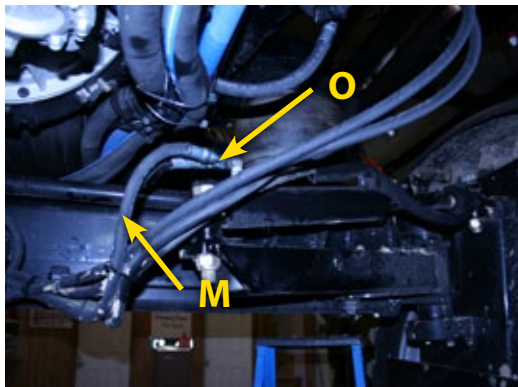
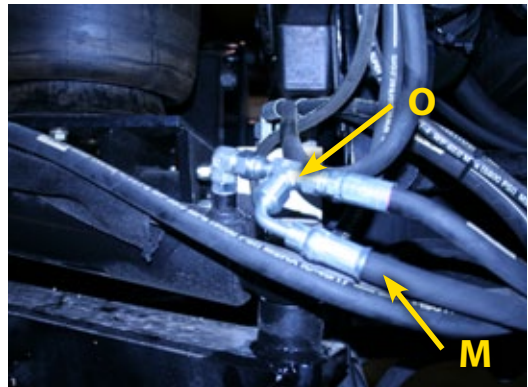
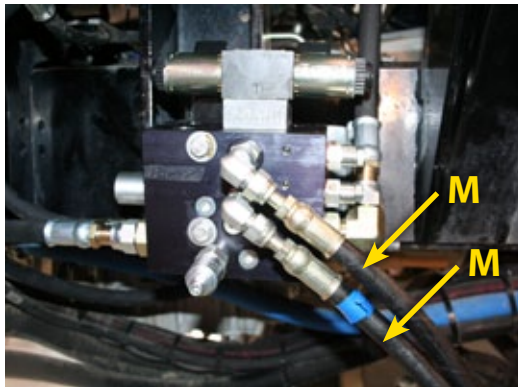

8. INSTALL STEERING DISENGAGE SWITCH (KIT 91-07011)

The steering disengage kit (U) is used to automatically disengage FieldPilot when the steering wheel is turned.

Remove front cover of steering column to gain access to the steering shaft. Using kit (U), attach magnets to the steering shaft. Position the sensor in the bracket to provide a 1/8" clearance between the sensor and magnets. Use extension cable (W) to connect the steering disengage sensor to the SCM harness.

Figure 1-12: Install Steering Disengage Switch (Kit 91-07011)

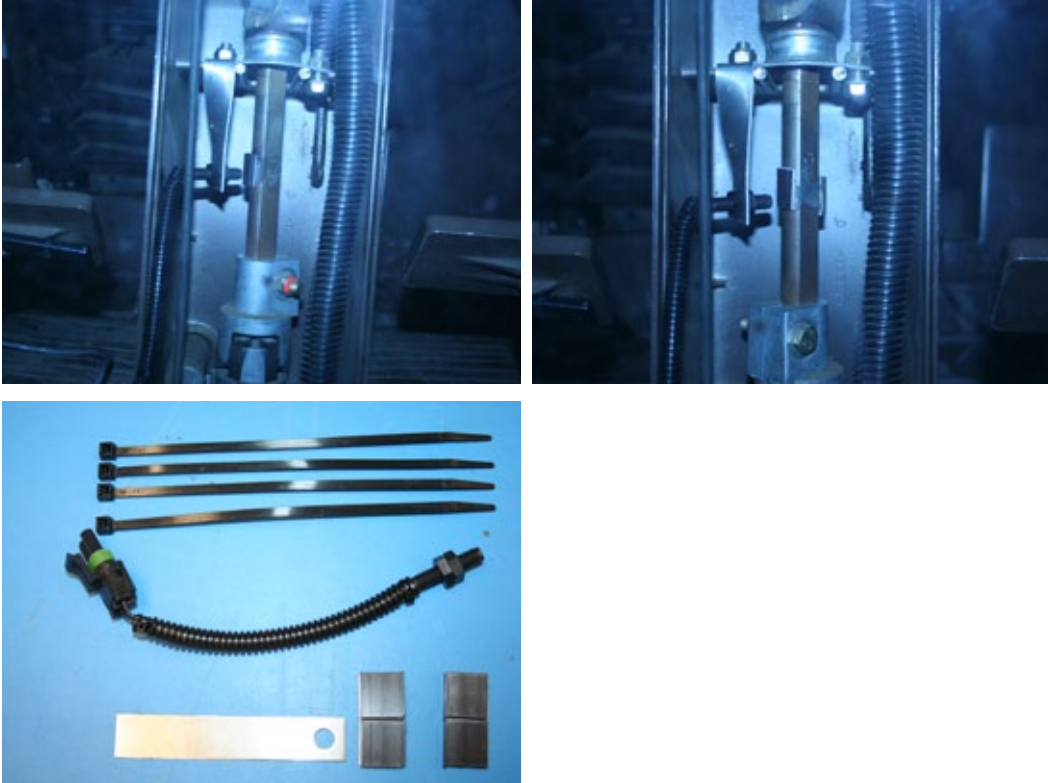

9. INSTALLATION OF ENGAGE/DISENGAGE SWITCH

Connect item **(A)** to the connector on the SCM harness labeled Remote Engage/Disengage. Install the push button in a location that is easily accessible during operation of the machine. This switch **(A)** is not required if the optional foot switch 32-04020 is used.

Figure 1-13: Engage/Disengage Switch



10. RECOMMENDED ELECTRONICS INSTALLATION

The Steering Control Module (SCM) should be securely mounted as level as possible to the floor. It must be mounted with the arrows pointing toward the direction of travel. The control console can be mounted to the preference of the operator. The GPS antenna should be mounted as far forward as possible on the cab on a metal surface of at least 4" square.

Figure 1-14: Recommended Electronics Installation

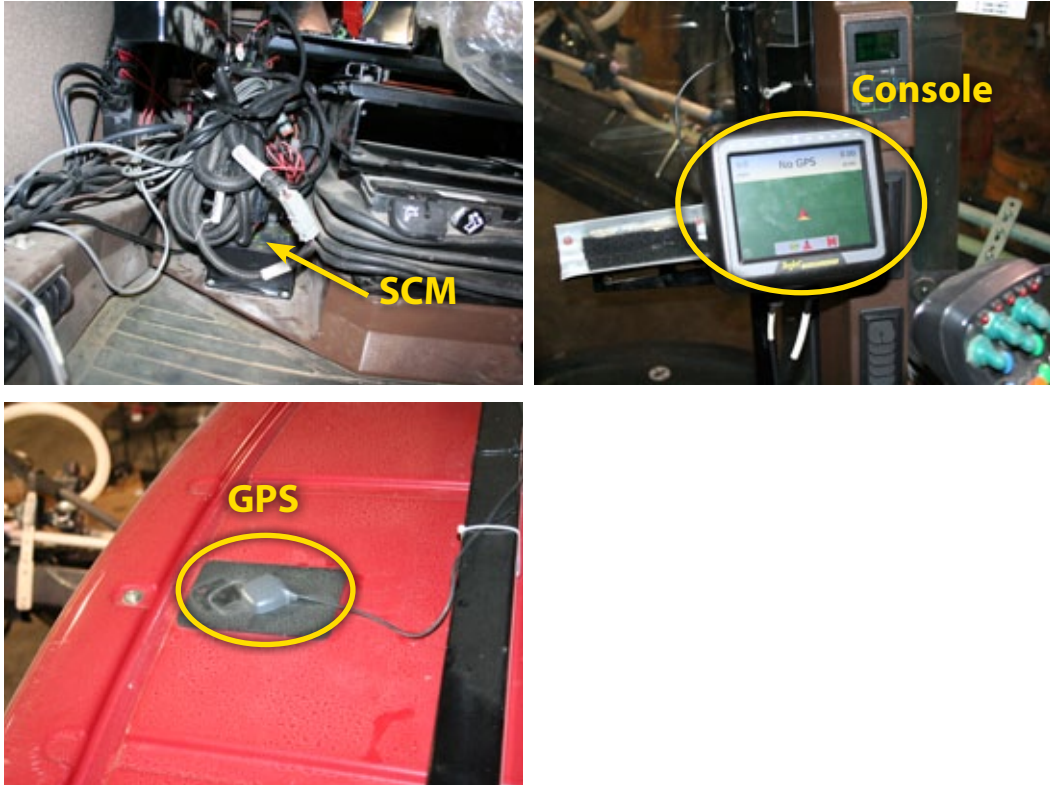

11. INSTALL VALVE CONTROL CABLE

Connect the valve control cable (E) to the FieldPilot valve and route into the cab through an access panel located on the right rear area of the cab. Do not be concerned at this time about which connector is connected to which solenoid coil.

Figure 1-15: Install Valve Control Cable

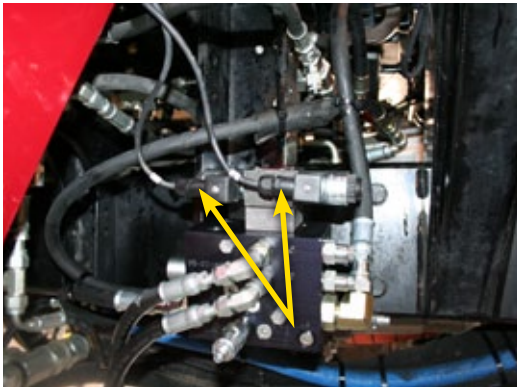

12. VERIFY OPERATION OF HYDRAULICS AND SET THE STEERING CONTROL RATE

Clean and pick up the area around the vehicle and make certain that it is safe to operate. Start the engine and check hydraulic connections for leaks. Rotate the steering wheel from one extreme to the other and back to center, check for leaks. While steering through the extremes of movement, check the cables and hoses for wear points and strain, adjust as necessary.

The final oil flow rate adjustment is accomplished through the Matrix console. The target lock to lock time is 7 seconds and the valve frequency is 110. Refer to the Matrix manual for further instructions.

NOTE: To activate the manual overrides, a tool such as a small screwdriver or allen wrench must be inserted into the end of the coil to depress the override button.



WARNING: PINCH POINT HAZARD! To prevent serious injury or death, avoid unsafe practice while manually operating hydraulic steering circuits. Keep others away and stay clear of mechanical steering linkages.

13. COMPLETE ELECTRONIC INSTALLATION

Refer to the owner's manual supplied with the automated steering system to complete the electronic installation and setup.

FIELDPILOT®

INSTALLATION MANUAL

A series of equipment-specific hydraulic installation kits have been developed to work in conjunction with your assisted steering system. This kit contains the necessary components and instructions to install assisted steering hydraulics on the Miller Condor. Please review this manual thoroughly before beginning the installation process.



1801 Business Park Drive
Springfield, Illinois 62703 USA
Tel: (217) 747-0235 • Fax: (217) 753-8426
www.teejet.com

A Subsidiary of  **Spraying Systems Co.®**

98-05160 R2
© TeeJet Technologies 2010