

TeeJet®

844-R Speed Compensated Application Control

User Guide



98-05047
R0

Table Of Contents

TABLE OF CONTENTS	2
INSTALLING THE SPEED SENSOR ASSEMBLY	4
STEP 1 - LOCATION	4
<i>Proximity Sensor (optional)</i>	4
STEP 2 - INSTALLING THE WHEEL MAGNETS.....	5
STEP 3 - INSTALLING THE MAGNETIC SENSOR	5
STEP 4 - CONFIRMING SPEED SENSOR INSTALLATION.....	6
<i>Magnetic Wheel Sensor</i>	6
<i>Radar</i>	6
POWERING CONSOLE ON/OFF	7
POWER ON.....	7
POWER OFF	7
OPERATING INSTRUCTIONS	8
APPLICATOR CHECKOUT	8
THE SPRAYING OPERATION	9
FEATURES	10
AREA/VOLUME DISPLAY	10
APPLICATION ALARM.....	10
NO FLOW ALARM.....	11
FLOW RATE FEATURE	11
BOOST MODE	12
<i>Boost Up</i>	12
<i>Boost Down</i>	12
AUTO POWER DOWN	13
PROGRAMMING GUIDELINES	14
IMPORTANT PRELIMINARY INFORMATION	14
SYSTEM SETUP MODE – TEEJET 844-R CONTROLLER	14
SELECTION OF WORKING UNITS	15
RESET TO DEFAULTS.....	15
FLOW METER PULSES.....	16
TIP SPACING.....	16
# OF TIPS.....	16
SPEED SENSOR CALIBRATION.....	17
<i>Proximity/Magnetic Pulses</i>	17
FLOW METER CALIBRATION	19
METHOD 1 – KNOWN VOLUME	19
<i>Step 1 – Known Value</i>	19
<i>Step 2 – Programming Calibration Number</i>	19
<i>Step 3 – Resetting Volume Counter</i>	19
<i>Step 4 – Spraying Known Volume</i>	19
<i>Step 5 – Entering a New Flow Meter Calibration Number</i>	20
<i>Step 6 – Double-checking the New Value</i>	20
METHOD 2 – KNOWN TIP SIZE METHOD	20
<i>Step 1 – Check Tip Size</i>	20
<i>Step 2 – Count Tips</i>	20
<i>Step 3 – Calculated Flow</i>	21

<i>Step 4 – Measure</i>	21
<i>Step 5 – Adjustments</i>	21
DISTANCE COUNTER	22
SIMULATED GROUND SPEED	22
<i>How To Use</i>	23
COMMUNICATIONS	23
MINIMUM PRESSURE SETTING.....	24
APPLICATION SETUP MODE.....	24
TARGET APPLICATION RATE	24
FLOW RATE SELECTION	25
CALCULATION STEPS.....	25
<i>Known Speed Calculation</i>	25
<i>Known Pressure Calculation</i>	26
DAILY FLOW METER MAINTENANCE.....	26
TROUBLESHOOTING GUIDE.....	27
QUICK REFERENCE GUIDE.....	29
SYSTEM SETUP MODE	29
APPLICATION SETUP MODE.....	30
FEATURES.....	30

Installing the Speed Sensor Assembly

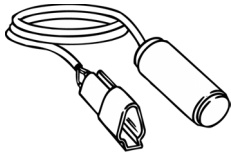

Components: Two magnets, Sensor with attached connector cable, and mounting hardware.

If you are installing a radar ground speed sensor, follow the instructions supplied with that unit.

STEP 1 - LOCATION

The speed sensor assembly should be installed on a non-driven wheel to avoid potential errors that are likely to occur from a slipping drive wheel. (Refer to Figure 1)

Proximity Sensor (optional)

An optional proximity sensor is available to use in cases where space is limited or for drive shaft mounting. The proximity sensor works by sensing any metal object. Mount the proximity sensor so that the sensor face is within 1/8 to 3/8 inch of the metal object being read. (Refer to Figure 2)

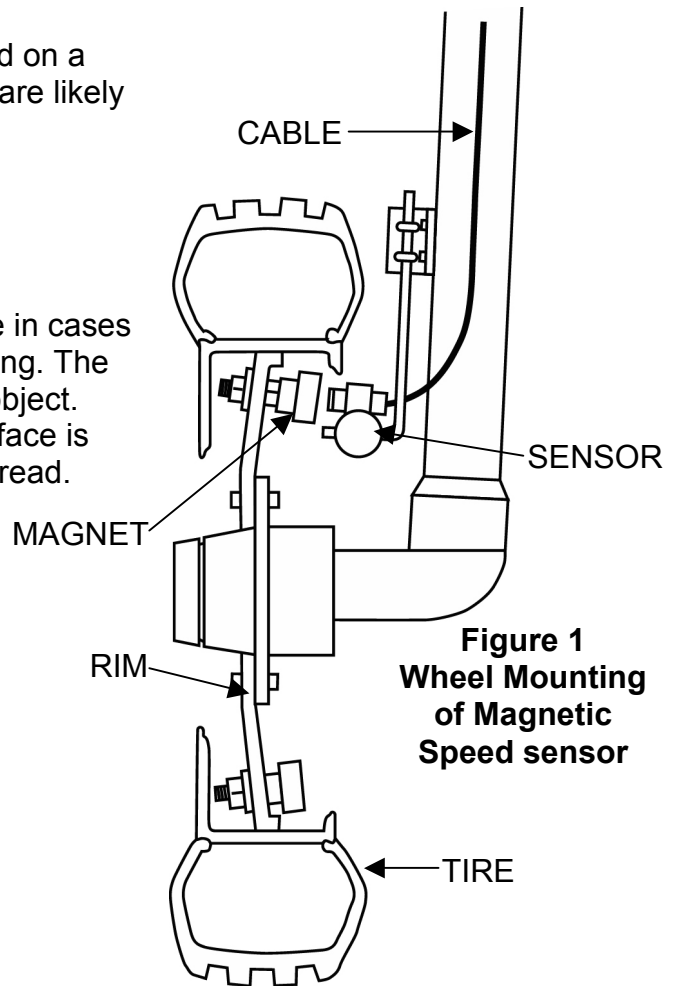

Figure 1
Wheel Mounting of Magnetic Speed sensor

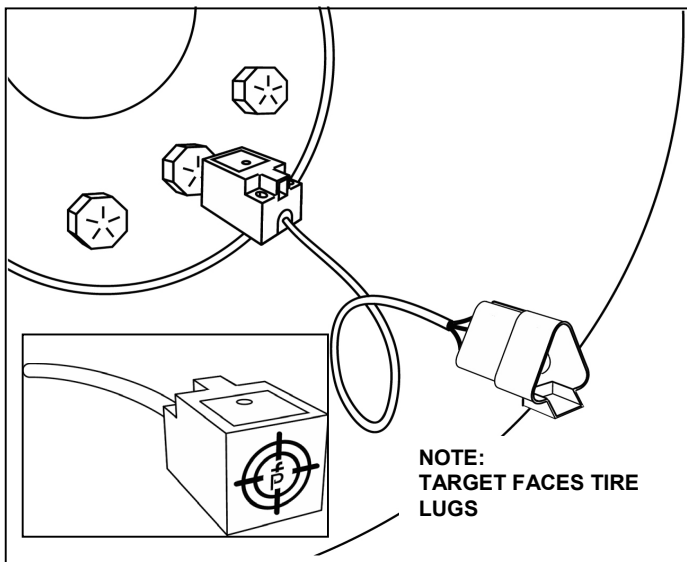

Figure 2

STEP 2 - INSTALLING THE WHEEL MAGNETS

Check for pre-drilled holes in the wheel rim. If pre-drilled holes are not available, layout a pattern as shown in figure 3 and drill two 3/8 inch holes, locating them near the outer rim, if possible, and 180° from each other.

Place the magnets into each of the two holes on the inside rim and securely fasten using the nuts and washers provided. (See Figure 4)

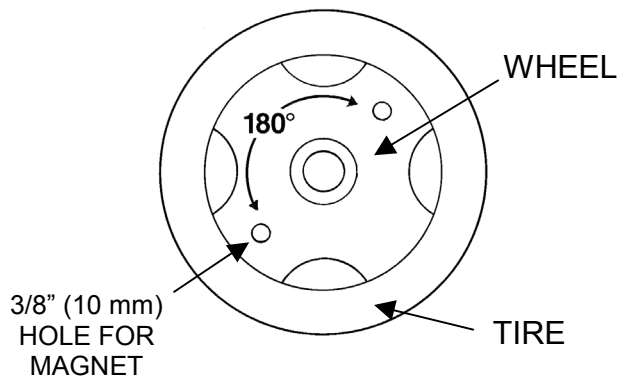

Figure 3
Magnet Locations

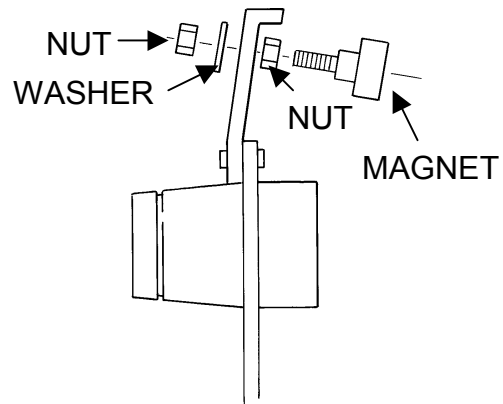

Figure 4
Magnet Assembly

STEP 3 - INSTALLING THE MAGNETIC SENSOR

Secure the flat, pressed L bracket of the wheel speed sensor kit to a vertical member near the non-driven wheel. Then secure the round, right angle steel bracket to the flat bracket with the two U-bolts and necessary hardware provided. Use the round, right angle bracket to secure the magnetic sensor mounting clamp. (See Figure 5)

Insert the magnetic sensor into the mounting clamp and position it to within 1/8 to 3/8 inch of the wheel magnet. Tighten the sensor clamp using the clamp screw per Figure 5A.

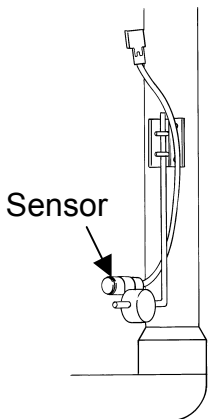

Figure 5
Sensor Mounting

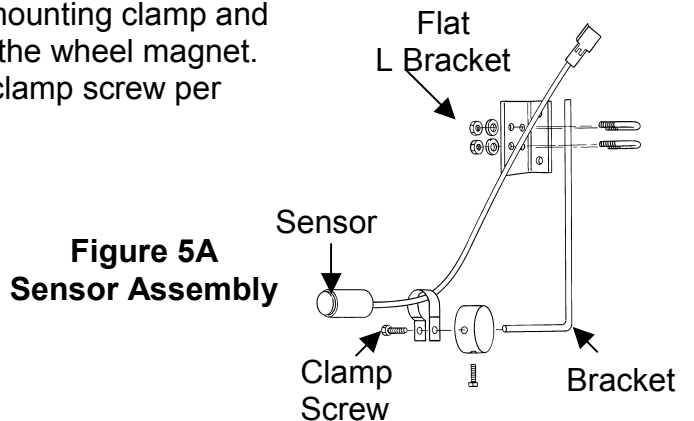

Figure 5A
Sensor Assembly

Your installation will likely vary from the example. It may be necessary to customize the installation to accommodate your specific machine. Keep in mind that the two magnets must be spaced an equal distance around the wheel. The magnetic sensor must be mounted in-line with the magnets and positioned within 1/8 inch to 3/8 inch from each magnet as they pass the sensor assembly.

STEP 4 - CONFIRMING SPEED SENSOR INSTALLATION

Magnetic Wheel Sensor

After the wheel or proximity sensor is installed and the 844-R console is mounted and powered up test the speed sensor installation. Connect the wheel speed or proximity sensor to the sensor cable and in turn connect the sensor cable to the 844-R console. When the connections are made, rotate the wheel on which the magnets are installed. If using a proximity sensor, you will be sensing metal objects and not magnets. Each time a magnet (metal object for proximity sensor) passes the sensor a red LED (orange LED for proximity sensor) on the back of the sensor will light. The LCD display on the console will also indicate a speed as the sensor receives and sends electronic pulses.

Radar

If a radar speed sensor is used, connect it to the speed sensor connector on the sensor end cable. An adapter cable will be necessary when using most radars and are available through your TeeJet 844-R dealer. The 844-R will automatically sense if the speed sensor is a wheel speed, proximity type, or radar type sensor during calibration. The 844-R is automatically adapted to most brands of radar speed sensors, provided that the appropriate adapter cable is used. If using a radar sensor, the 844-R will display *RAD* during the calibration procedure.



Powering Console On/Off

POWER ON

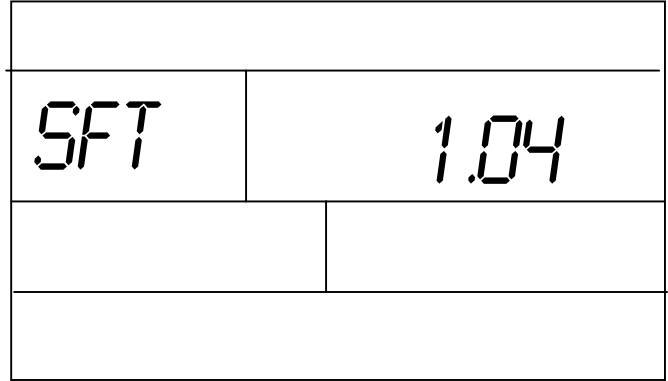
- ✓ To power the 844-R on press the  key once.
- Initially the console displays the software version in the top display.
- After 5 seconds the display shows the normal operating view.



POWER OFF

- ✓ To manually power the console off, press the  and  keys simultaneously.
- The console saves any new information (area and volume counters) to memory and powers off.

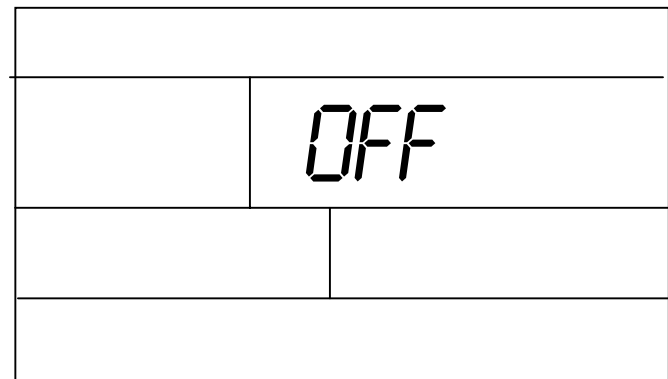

The console also has an Auto Power Down feature. When the master switch is “off”, and no buttons are pressed for approximately 10 minutes, the 844-R will automatically power down.

Note: Both “Delivery” and “Agitation” switches still power either pump even if console is “off”.

Operating Instructions







APPLICATOR CHECKOUT

Before spraying, check all connections related to the Control System. Be sure connections are made and the sensors and cabling are properly secured.

Very Important: Whenever working around chemicals, be sure to wear protective clothing and eyewear.

Partially fill the applicator tank with water to purge the system of air and to make a visual check of the liquid outlets to be sure liquid is exiting each outlet as intended.

Follow these steps, in sequence, being sure the Delivery Switch is in the “OFF” position:

- ✓ Be sure the tank shut-off valve is open.
- ✓ Switch the computer on by pressing the  key.
- ✓ Press the  Auto/Man key so that the red LED light indicates “MAN” mode.
- ✓ Now, toggle the Delivery switch to “ON”.
- ✓ Adjust the pressure with the  and  keys. The pressure should increase when you press the  key and decrease when you press the  key.

At this point, the applicator is activated and each micro-tube or orifice can be checked.



- ✓ Now press the  Auto/Man key so that the red LED light indicates “Auto” mode. The control console should regulate to the target application rate for the simulated speed indicated. See “Simulated Ground Speed” in the System Setup section of this manual for instructions on using simulated speed.

To stop applying, toggle the Delivery switch to “OFF”.

The above steps provide a quick way to check out your applicator and control system.

THE SPRAYING OPERATION

The sprayer tank is filled and the solution thoroughly mixed. The application rate and proper nozzles have been determined. The controller has been programmed with the sprayer and application information.

- ✓ Turn the control console on by pressing the  key.
- ✓ The  Auto/Man key should be switched to “AUTO”.
- In the Auto mode, when the Delivery switch is “OFF”, the target application rate as well as the target symbol is displayed on the console display. When the Master boom switch is “ON”, the actual rate is displayed and the target symbol no longer appears.
- While spraying with the Delivery switch “ON”, the display always displays the actual application rate, vehicle speed, application area covered/total volume applied and calculated pressure. Note: If the application system is equipped with pressure gauge, the pressure gauge may read differently than the calculated pressure shown on the console. This does not necessarily indicate a problem.
- ✓ As you get to the point where application will begin, turn the Delivery switch to the “ON” position. This activates the delivery pump. Moderate changes in vehicle speed don't affect your application rate, because such changes are compensated for with automatic pressure adjustments by the controller.

If it is necessary to stop, turn the Delivery switch to “OFF”.

Alarm warnings may occur momentarily while the pressure regulating valve is searching for a new setting after a significant speed or rate change. However, if the alarm stays on for a longer time, the valve may have reached its limit and your system is unable to regulate flow beyond the limit.

Features

AREA/VOLUME DISPLAY

The 844-R Sprayer Control counts application area and measures the total volume applied while the master boom switch is in the “ON” position.

- The area counter measures treated acres and is dependent on the values programmed for the # of outlets and the tip spacing.
- The volume measure is dependent on the signal from the flow meter.

The lower right of the display window shows:

- Volume Sprayed and Area Covered (alternating every 3 seconds).

To clear the area counter/volume measure:

- Be sure the Delivery switch is in the “OFF” position
- Press and hold the **+** or **-** keys for 3 seconds.

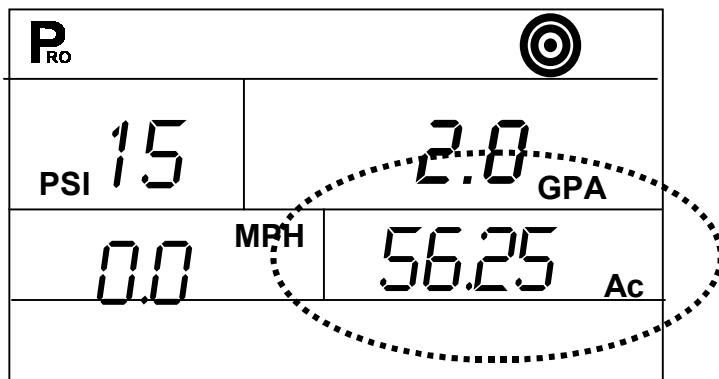

Note: The area/volume measure can only be cleared with Delivery switch turned “OFF”.

APPLICATION ALARM

If the 844-R senses a continuous discrepancy of 10% or more between the Target Application Rate and the Actual Application Rate:

- The application rate units flash. This alerts the operator to a problem with the applicator, plumbing, operation or programming.

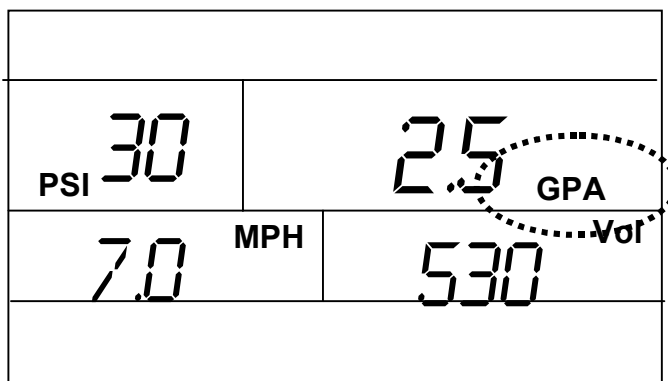

NO FLOW ALARM

If the 844-R stops receiving pulses from the flow meter

- The turbine symbol flashes at the top of the display.

This alarm indicates that there is a problem with the flow meter or cabling.

This alarm occurs only when the Master boom switch is "ON".

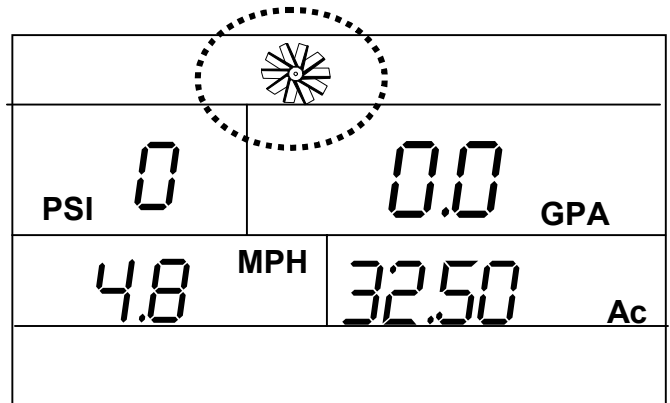

FLOW RATE FEATURE

The 844-R Sprayer Control measures a flow rate moving through the flow meter in GPM {Imp GPM}. This feature is activated by pressing and holding the **P_{Ro}** key while spraying in the normal operating mode. The flow rate display replaces the area/volume display in the lower right portion of the display.

Any time the **P_{Ro}** key is pressed while spraying in the normal mode the flow rate is displayed. Releasing the **P_{Ro}** key causes the display to return to area/volume.

This feature can be used for tip calibration or for calibrating the flow meter. Refer to page 19 of this manual for the flow meter calibration procedures.

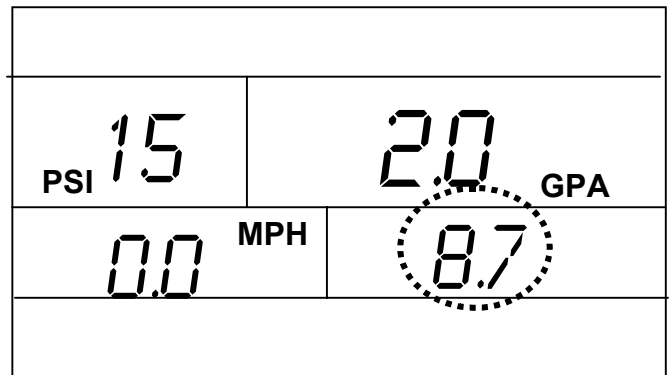



BOOST MODE

The 844-R is capable of boosting the target application rate either up or down in 10% increments.



Boost Up

To activate the boost up mode:

- ✓ Press the  key.
- ✓ Each subsequent pressing of the  key boosts the target rate up 10%.
- The amount boosted up is shown on the display temporarily (approx. 2 seconds).
- The target symbol flashes anytime that you are in the boost mode to alert the operator of the “off target” condition.



		
UP	2.4	GPA
20	39.50	Ac

To return to the target application rate:

- ✓ The operator can use the  key to get back in 10% increments
- ✓ The operator can push the  and  keys simultaneously to get back to the target in one step.

Boost Down

To activate the boost down mode:

- ✓ Press the  key.
- ✓ Each subsequent pressing of the  key boosts the target rate down 10%.
- The amount boosted down is recorded on the display.
- The target symbol flashes anytime that you are in the boost mode to alert the operator of the “off target” condition

		
DN	1.4	GPA
30	877	Vol

To return to the target application rate:

- ✓ The operator can either use the **+** key to get back in 10% increments
- ✓ The operator can push the **+** and **-** keys simultaneously to get back to the target in one step.

AUTO POWER DOWN

The 844-R console is designed to power itself off after 10 minutes of no inputs. This feature keeps the console from draining the battery on the sprayer if the operator inadvertently leaves the console powered on for an extended period. This only occurs when the Master boom switch is turned OFF and the console is not receiving inputs from any of the sensors (the sprayer is inactive).

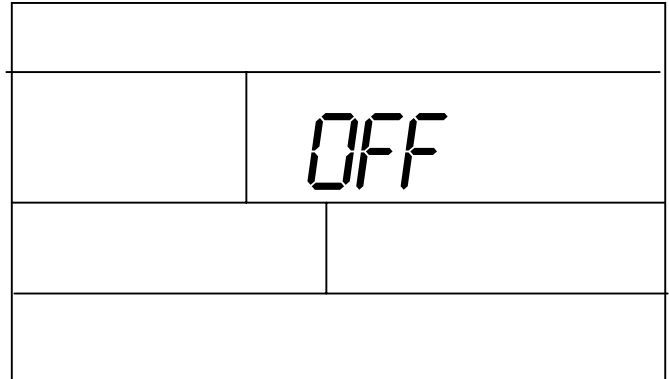

To manually power the console off, refer to the Powering Console On/Off section of this manual.

Note: When the console display power is “off”, the “Delivery” and “Agitation” switches can still be operated.

Note: When in the user setup mode, the automatic power down feature is disabled. However, after 10 minutes without keyboard activity, the console automatically saves all program changes and exits the program mode. At this time, the automatic power down feature begins counting and will shut the console off after 10 minutes.

The programming of the 844-R is divided into two programming categories; System Setup Mode and User Setup Mode.









- The System Setup Mode contains the programming steps that customize the controller to the applicator or it’s components. These include calibration steps and parameters that, once programmed, rarely change.
- The Application Preset Setup Mode contains target application rate and orifice or micro tube capacity settings, which are more frequently changed.

Programming Guidelines

Make sure that all hardware components are properly installed and tested. Before the programming process starts, confirm that the console and all sensors are working properly.

IMPORTANT PRELIMINARY INFORMATION



Before starting, we recommend that you review the following Programming Guidelines that control the programming process:

- To enter the program mode, see the appropriate program section you wish to enter in this manual. The delivery switch must be in the “off” position to enter any program mode.
- To **exit** any program mode press and hold the  key for 3 seconds, your changes are stored and the computer exits the program mode. This action can be done at any time during the program process.
- To increase the value of a programmable digit, press the  key. To decrease the value, press the  key. These keys are located directly to the right of the display. For some programming steps, pressing and holding the  or  key changes the programmable value rapidly. Pressing the  or  key once changes the value by one increment.
- Pressing the  key advances you to the next programming step. After the last programming step, the console completes the program loop and returns to the first programming step.

Due to differences in fonts, some letters on the displays shown in this manual are not identical with the corresponding letters on the display of the controller.

System Setup Mode – TeeJet 844-R Controller

The System Setup Mode contains the programming steps that customize the controller to the applicator or its components. These include calibration steps and parameters that, once programmed, rarely change.

To enter the Program Mode, starting from the normal operating mode, press and hold the  and  keys and tap the  key twice. Release all keys. The first programming step should appear on the display.

SELECTION OF WORKING UNITS

In this step select the units you will be using.

The 844-R is capable of working in:

- GPA (US Gallons Per Acre)
- IMP (Imperial Gallons Per Acre),

- ✓ Use the **+** and **-** keys to select the appropriate units.
- ✓ Press the **⏏** key to accept the value and advance to the next program step.

P R0	
	US

RESET TO DEFAULTS

*******THIS STEP MAY NOT APPEAR*******
If you did NOT make any changes to the units, this step is skipped and you are automatically advanced to the Speed Sensor Calibration Step.

If a change is made to the units in the first programming step, before advancing to the next step the console asks if you want to reset all the program parameters to defaults specified for the units chosen.

- ✓ Use the **+** or **-** key to select either yes or no.
- ✓ Press the **⏏** key to begin resetting or advance to the next step.

P R0	
RES	YES
DEF	

FLOW METER PULSES

In this step the flow meter calibration number can be entered manually from the factory calibrated meter. Your controller is preset to match the flow meter installed on the Redball pump unit. If changes are necessary:

- ✓ Use the **+** or **-** keys to modify the value on the display to match the tag on your flow meter.
- ✓ Press the **RO** key to advance to the next step.

P RO	
	4000

TIP SPACING

Enter the spacing between the spray nozzles or micro tubes in Inches

- ✓ Use the **+** or **-** keys to adjust the value.
- ✓ Press the **RO** key to advance to the next step

P RO	
	30

OF TIPS

Enter the number of individual micro tubes or orifices on the applicator.

- ✓ Use the **+** or **-** keys to adjust value.
- ✓ Press the **RO** key to advance to the next step

P RO	
5 E 0	12
1	

SPEED SENSOR CALIBRATION

During Speed Calibration, the 844-R automatically senses if a Wheel Speed or Radar Speed Sensor is being used.

Proximity/Magnetic Pulses

The speed sensor must be calibrated in order to provide the proper speed and area readings. The value for this step is the number of pulses generated by the speed sensor in 300 ft.

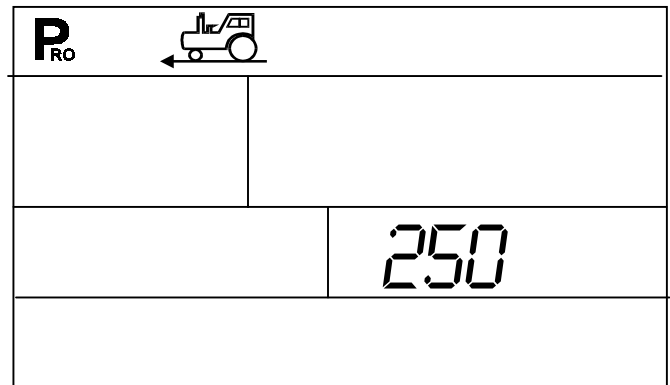

Automatic Calibration:

- ✓ Mark off a distance of exactly 300 ft.
- ✓ Press and hold the **+** and **-** keys simultaneously to activate the auto calibration mode.

When the auto calibration mode is been activated, "CAL" is displayed at the lower right of the display.

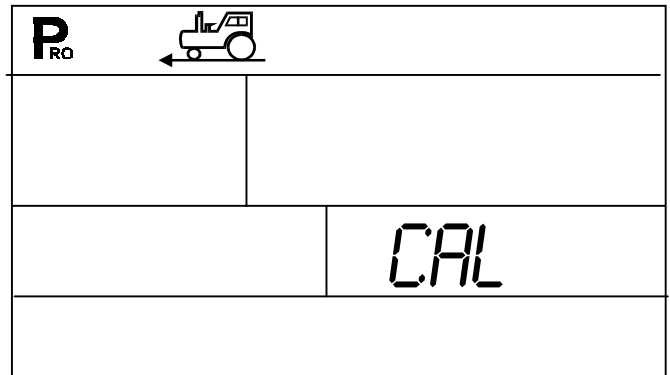

- ✓ Now start driving toward the start point of the of 300 ft. course.
- ✓ As you cross the start point press the **+** key once to begin the calibration process.
- ✓ Continue across the course as the 844-R counts the pulses created by the speed sensor.
- ✓ As the end point is crossed, press the **+** key once. The number displayed is your speed calibration number.
- ✓ If the console determines that a radar speed sensor is connected, "RAD" will be displayed in the lower left quadrant of the display.

The speed at which you drive over the course is not important.

It is best to repeat the automatic speed calibration process at least twice and use the average of the speed calibration numbers.

To manually enter the radar calibration value, first press the Auto/Man key to put the console into radar mode. When the control console is in the radar mode, "RAD" is displayed in the lower left of the console display. Now use the **+ or **-** keys to adjust the value.**

- ✓ Once the correct value is been entered, press the **P_{R0}** key to validate this value and advance to the next step.

If the auto calibration mode is been activated, no other functions are possible until the console receives speed pulses for calibration. To deactivate the auto calibration mode, press the **+ key until a number is displayed.**

Flow Meter calibration

The flow meter supplied with your system has been calibrated at the factory and under normal circumstances there may be no need to re-calibrate it. However, the factory calibration setup may not reflect specific sprayer plumbing. Before spraying actual chemicals, the flow meter should be checked for proper calibration. To do so, use either of the following methods:

METHOD 1 – KNOWN VOLUME



Step 1 – Known Value

Select a known volume of water (n) to be pumped through the flow meter. In these steps, 10 US gallons {8 Imperial gallons} will be used as an example. The specific volume you use is not important, although larger volumes generally produce more accurate results.

Step 2 – Programming Calibration Number

Go into the System Setup Mode and advance to the Flow Meter Calibration step (flashing turbine at the top of the display). In this programming step, enter (n) 10 US gallons {8 Imperial gallons} as the calibration number. Exit the System Setup mode by pressing and holding the  key for five seconds.

Step 3 – Resetting Volume Counter

Reset the total volume number that is displayed in the lower right portion of the display. (Display alternates between Ac covered and the volume sprayed through the flow meter). To reset this number, press the  and  keys simultaneously for three seconds or until you see the values reset to zero.



Step 4 – Spraying Known Volume

Engage the pump on the sprayer, flip the Master Boom Section of the 844-R to “ON” (make sure at least one boom section switch is on), and pump exactly (n) 10 US gallons {83 Imperial gallons} through the flow meter. When the known volume is reached, shut the Master Boom Switch “OFF”.

Step 5 – Entering a New Flow Meter Calibration Number

The number displayed in the lower left hand corner of the display is the new flow meter calibration number. Record this number, enter the System Setup Mode and advance to the Flow Meter Calibration Number step. Enter the new value from the test into this step and exit the System Setup Mode.

Step 6 – Double-checking the New Value

Double-check the new value by spraying a larger volume of water, such as 100 US gallons {83 Imperial gallons} through the flow meter. Before spraying the larger volume, reset the memory counters by depressing and holding the  and  keys simultaneously for three seconds.

NOTE: After double-checking the new calibration number, if the volume shown is more than +/- 3% in error, change the flow meter calibration number in the system Setup Mode by the % difference it is in error.

Example: If the volume displayed is 5% too high, then increase the flow meter calibration number by 5%. Example: If the volume displayed is 5% too low, then decrease the flow meter calibration number by 5%.

METHOD 2 – KNOWN TIP SIZE METHOD

Step 1 – Check Tip Size

Determine the size tip on the sprayer. An actual flow collection should be done on a representative sample to ensure the tips are not worn. To do this, set the boom at 40psi. This must be pressure at the tips (i.e. use manual pressure gauge mounted on the boom). Collect flow for 1 minute from 1 tip.

Example: XR8004 tip should spray 0.4 gallons in 1 minute {0.32 Imp Gal}

Step 2 – Count Tips

Count the total number of tips to be used for measure. You can use 1 boom section, 2 boom sections, etc.

Example: Boom Section 1 has 10 tips

Step 3 – Calculated Flow

Multiply the number of tips to be measured by the size (or individual flow rate) of each tip.

Example: 10 tips x 0.4 GPM {0.32 Imp GPM} = 4GPM {3.2 Imp GPM}

Step 4 – Measure

Turn the controller on to activate pump. Toggle on the Master Boom Switch and the number of sections to be measured. Insure that the pressure at the boom is maintained at 40PSI. While spraying, press and hold the **P_{Ro}** key in. Look at the lower right display to see if the measured flow matches the calculated flow.

Step 5 – Adjustments

If the measured flow is higher than the calculated flow, the flow meter calibration number needs to be decreased.

If the measured flow is lower than the calculated flow, the flow meter calibration number needs to be increased.

Example: Calculate flow is 4.00 GPM {3.20 Imp GPM};
measured flow is 3.6 GPM {2.88 Imp GPM}

$$4.0 \text{ GPM} - 3.6 \text{ GPM} = 0.4 \text{ GPM} \quad \frac{0.4 \text{ GPM}}{4.00 \text{ GPM}} = 0.1 \times 100 = 10\%$$

$$3.2 \text{ Imp. GPM} - 2.88 \text{ Imp GPM} = 0.32 \text{ Imp GPM} \quad \frac{0.32 \text{ Imp GPM}}{3.2 \text{ Imp GPM}} = 0.1 \times 100 = 10\%$$

Decrease the flow meter calibration number by 10%.

If original number was 650, enter 585 for this programming value.

DISTANCE COUNTER

This step is a feature, not a calibration step. No specific value needs to be entered here for the controller to operate correctly.

- ✓ This feature measures distance in feet.
- ✓ It can be used to confirm Automatic Speed Calibration (see note below).
- ✓ To activate the counter, press the **+** key.
- ✓ To stop the counter, press the **+** key again.
- ✓ To clear an existing distance, press and the **+** and **-** keys simultaneously.

P R0	
FT	45

SIMULATED GROUND SPEED

To confirm Automatic Speed Calibration, first complete the calibration procedure. Advance to Distance Counter step. Drive across the same 300 foot course. Begin counting at the start point and end at the finish point. Distance measured should be 300 feet (+/- 6 feet).

Simulated ground speed allows you to check out the functions and operations of the console and of the pump unit, spraying water, without actually moving the applicator. This can and should be done prior to any actual application activity.

- ✓ Use the **+** and **-** keys to adjust the value.
- ✓ Press the **P** key to advance to the High Simulated Speed step.

P R0	
SIM	0.0
SP	

How To Use

To activate the simulated speed, set a value other than zero in the Simulated Ground Speed step as indicated above. Upon exiting the programming mode, the simulated ground speed is in effect, and appears in the speed area of the display (lower left quadrant). The tractor symbol flashes when a simulated speed is in effect.

Once the sprayer begins moving and the 844-R receives actual speed pulses, the simulated speed feature is deactivated. If you are using a Radar Speed Sensor, disconnect the Radar connection from the main console. Because of the sensitivity of this speed sensor, any movement can disable simulated speed.

COMMUNICATIONS

This step lets you select what type of communication to use (if any).

The choices available are:

- ✓ "NO COM" (no communications)
- ✓ "LOG" (Downloading to a PC on the go capability)
- ✓ "GPS" (Global Positioning System / Variable Rate communication capability)
- ✓ "PRT" (printing),

- ✓ Use the **+** and **-** keys to select the type of communication you are using.
- ✓ Press the **PRO** key to advance to the next step.

PRO	
NO	COM

MINIMUM PRESSURE SETTING

Set the minimum pressure that the controller will be allowed to regulate to. Sometimes when the applicator speed slows down, the control system will regulate the pressure so low that it falls below the pressure required to open the check valves on the individual nozzle bodies.

This is typically set to the minimum recommended pressure nozzle body check valves.

- ✓ Use the **+** or **-** keys to adjust the minimum pressure.
- ✓ Press the **P_{RO}** key to advance to the next step.

I.e. If this step is set to 15 psi the console, in automatic mode, will not regulate pressure below 15 psi.

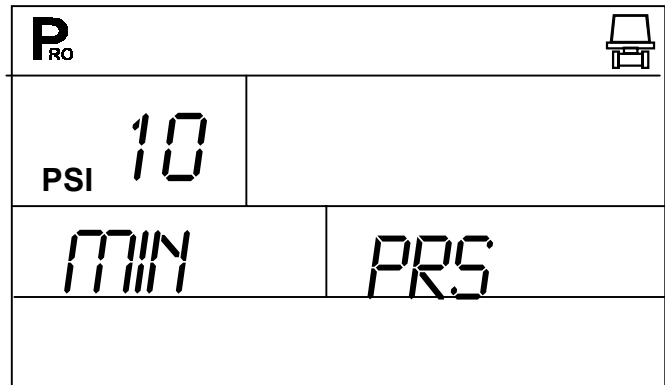

Application Setup Mode

To access the Application Preset Setup Mode, press the **P_{RO}** key two times. (Master switch must be OFF)

TARGET APPLICATION RATE

After entering the Application Setup Mode, the Target symbol should be flashing. If it is not, press the **P_{RO}** key 3 or 4 times until the Target symbol is flashing, indicating that the target rate is ready to be changed.

- ✓ Press the **+** key to increase the target rate or **-** key to decrease the target rate.
- ✓ Press the **P_{RO}** key to accept the value and advance to the next step.

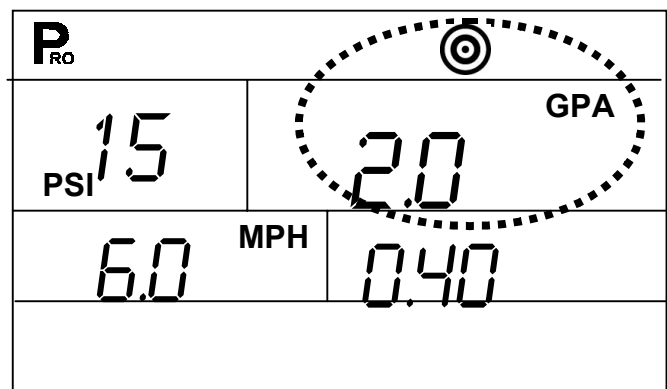

FLOW RATE SELECTION

Next, the tip icon in the top section of the display starts flashing. This value represents the flow capacity of a single orifice or Micro Tube in Gallons Per Minute (GPM) at 12 PSI. Using flow capacity information from the manufacturers documentation, set this to the correct value.

- ✓ Use the **+** or **-** keys to change the value.
- ✓ Press the **▶** key to advance to the next step

P_{RO}			
PSI	12	2.0	GPA
6.0	MPH	0.019	

CALCULATION STEPS

The following two steps are calculation or informational steps only. They have no effect on the application or operation of the console.

Known Speed Calculation

Adjust the speed value to the desired application speed. The pressure value automatically adjusts to the approximate pressure required to apply the desired application rate at the speed selected. This allows the opportunity to be sure the application values are in the range expected prior to the actual application.

- ✓ Use the **+** or **-** keys to adjust the indicated speed to a value that you will be traveling at.
- The console immediately calculates what the pressure should be to maintain the target application rate at this speed.
- If the pressure is too high, substitute a larger set of orifices or Micro-Tubes, or slow down.
- If the pressure is too low, substitute a smaller set of orifices or Micro-Tubes, or speed up.

P_{RO}			
PSI	12	2.0	GPA
6.0	MPH	0.019	

- ✓ Pressing the **P_{RO}** key again will take you back to the pressure calculation step.

Known Pressure Calculation

Adjust the pressure value to the desired operating pressure and the speed value will automatically change to reflect the approximate speed required to achieve the programmed target rate at the pressure selected. This gives an indication of the speed range expected at the desired operating pressure range.

- ✓ Use the **+** or **-** keys to adjust this value.
- The console immediately determines what the operating speed should be to achieve the target application rate at this pressure.
- If the speed indicated is too high, a set of smaller orifices or Micro-Tubes is needed.
- If the speed indicated is too low, a set of larger orifices or Micro-Tubes is needed.

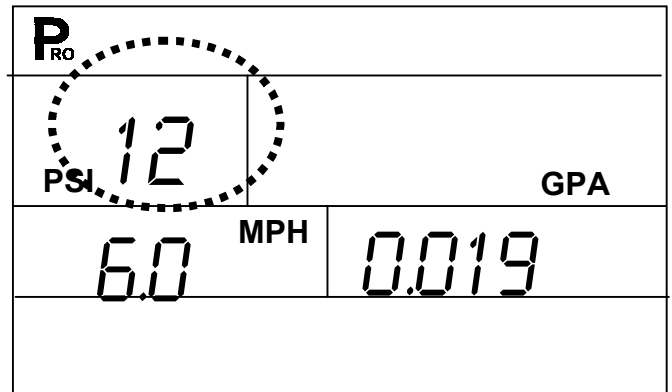

- ✓ Press the **P_{RO}** key to advance to the speed calculation step.

Continue to try different speed, pressure and tip combinations. Once the correct setting is determined:

- ✓ Exit the Application Preset Mode by pressing and holding the **P_{RO}** key for 2 seconds.



Daily Flow Meter Maintenance

- ✓ Remove flow meter from the system
- ✓ Use a soft bristle brush to scrub the tube clean
- ✓ Use clean water to wash any impurities out of the flow meter
- ✓ Reinstall flow meter

Troubleshooting Guide

CONDITION	POSSIBLE CAUSES	SOLUTION
1. Application Rate Units (GPA) continually flash on/off.	A. Continuous discrepancy of 10% or more between Target Application Rate and Actual Application Rate.	Check all components and programming steps related to flow.
	PROGRAMMING	
	B. Flow meter pulses	In the System Setup Mode, move to the Flow Meter Pulses section on page 16. Enter the factory calibrated flow meter pulse rate located on the tag accompanying the flow meter.
	C. Nozzle Setup	In the Application Setup Mode, move to the Flow Rate Selection section on page 25. Enter the flow rate in GPM at 12 psi of the tips. If the tips have been used and possibly worn, measure the flow in Gallons Per Minute at 12 psi and enter that value in the step above.
	D. Number of spray tips	In the System Setup Mode, move to the # of Tips step on page 16. You must enter the correct number of spray tips or micro tubes.
2. Application Rate Units continually flash on/off.	A. Continuous discrepancy of 10% or more between Target Application Rate and Actual Application Rate	Check all components and programming steps related to flow.
	MECHANICAL	
	b. Plugged Tubes	In the event of plugged tubes, remove and clean with water and compressed air.
	C. Wrong capacity tubes	All tubes should be of the same capacity (Flow Rate).
	D. Flow meter plumbed incorrectly	A flow directional arrow is located on the body of the flow meter. Plumb the arrow in the direction of the flow. The flow meter must be mounted 10' to 12' from other pipe fittings. Generally, the flow meter works better when mounted in a vertical position with the flow being directed up.
3. Flow meter turbine signal continually flashes on/off. 	A. No flow meter pulses	Check to ensure that the delivery pump has been engaged while trying to spray. Check cabling for any loose connections.
4. Actual total volume applied, in GPA, does not match the total area covered	A. Speed sensor not calibrated correctly	Recalibrate the magnetic or radar speed pulses in the Speed Sensor Calibration section on page 17.
	B. Incorrect nozzle spacing	Check the Tip Spacing section in the System Setup Mode on page 16 to ensure the correct nozzle spacing has been entered. This number should reflect the distance between nozzles, in inches.
Continued on next page		





Troubleshooting Guide (Cont.)

	C. Flow meter pulses incorrect	In the System Setup Mode, move to the Flow Meter Pulses section on page 16. Enter the factory flow meter pulse rate located on the tag accompanying the flow meter.
	D. Speed sensor installed incorrectly	<p>One or more of the wheel sensor magnets are not consistently sending a pulse to the monitor.</p> <p>The distance between the sensor and the magnets is incorrect. Ground debris can accidentally move the sensor out of position. The red LED on the back side of the sensor should be lit when placed within the correct distance from the magnets. (See Installing the Speed Sensor on page 4)</p> <p>A proximity sensor has an orange LED on the top of the sensor that should be lit when placed within the correct distance from the sensing surface.</p>
	E. Radar incorrectly installed	Precise installation of the radar is critical to its working correctly. Thoroughly review the manual provided with the radar sensor you are using.
5. No regulation in Auto mode	A. No speed sensing	Check speed sensor to ensure it is sending pulses to the controller. Check the Speed Sensor Calibration section in the System Setup section on page 17 to ensure speed sensor is correctly calibrated.
	B. Regulating valve malfunction	<p>Check wiring from controller to the regulating valve. Make sure there is voltage to the regulating valve.</p> <p>Both wires leading to the regulating valve are 12V (+). With the Master Switch on, and the console set to MAN mode when either the  or  key is pushed, the appropriate wire goes to ground (-) to complete the circuit.</p>

Quick Reference Guide

SYSTEM SETUP MODE





- The Delivery switch must be off. Press **+** or **-** keys while simultaneously pressing the **P** key. Press the **P** key again to enter the System Setup Mode.

Step	Display	Description	My Values
Units	<i>US, IMP</i>	Select US or Imperial gallons for your application units by using + or - keys. Proceed to next step with P key.	
Flow Meter Pulses		Flow Meter Pulses; Value from flow meter label. Adjust by using + or - keys. Proceed to next step with P key.	
Nozzle Spacing		Nozzle (or row) spacing; Distance between spray nozzles or micro tubes in inches. Proceed to next step with P key.	
Tips per boom section		# of tips or micro tubes on the machine. Adjust with + or - keys. Proceed to next step with P key.	
Speed Calibration		Speed Calibration. Change with + and -, or to auto calibrate press + and - simultaneously to clear value, then drive 300 feet and press P .	
Distance Counter	<i>FT</i>	Not a calibration step, but allows you to measure distance in feet. Press + key to start counting, press + key again to stop counting. Proceed to next step with P key.	
Simulated Speed		Enter the desired simulated ground speed using + or - keys. Proceed to next step with P key.	
Communications	<i>NO CON</i>	Select the communications mode. Proceed to next step with P key.	
Minimum Pressure	<i>MIN PRS</i>	Sets the minimum pressure to which the controller will regulate. The controller will not regulate below this pressure.	

- To exit the System Setup mode, press and hold **P** for 3 seconds at any point in programming process.

APPLICATION SETUP MODE







- The Master boom switch must be off. Press the  key twice to enter the Application Setup Mode.

Step	Display	Description	My Values
Target Application Rate		Target application rate (GPA). Use the + and - keys to adjust the value. Go to next step with  button.	
Calculation Step	All operating information displayed with Pressure or Speed values flashing	Diagnostic tool only. Use the  or  keys to adjust the flashing values (pressure or speed). Changes to spraying parameters will be calculated immediately. To change adjustable value (flashing value) depress the  key.	

- To exit the Application Setup Mode, press and hold the  key for 3 seconds at any point in the programming process.

FEATURES

Following are useful features of the 844-R Sprayer Control and how to use them.

Features	Description
Boost Mode	Percentage increase or decrease in chemical application. Activated by depressing either the  or  keys while applying in Auto Mode by. Each subsequent depression of the  key will increase the application rate by 10%. Each subsequent depression of the  key will decrease the application rate by 10%.
Area/Volume Display	Application area (Ac) and total volume (Gal.) applied will be alternately displayed at the lower left of the display. To clear these values (both are cleared together) the master boom switch must be "off", then simultaneously depress the  or  keys and hold for three seconds.
Instantaneous Flow Rate	The instantaneous system flow rate can be measured and displayed. While applying (Delivery switch in 'on' position), press the  key

NOTES

Midwest Technologies Illinois, LLC
2864 Old Rochester Road
Springfield IL 62703 USA
217-753-8424